

Weldable

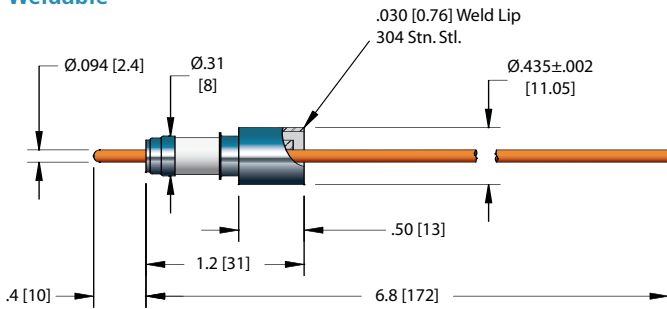

ISO KF - NW16KF

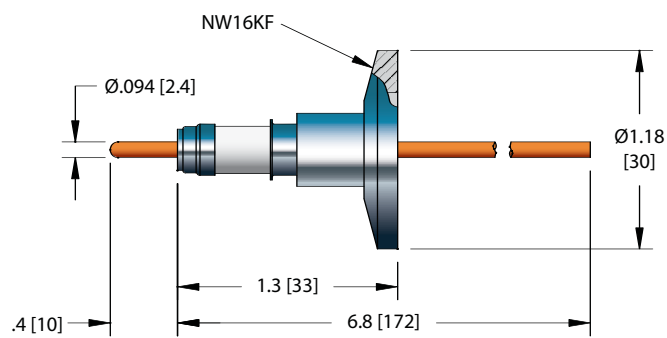

ConFlat - NW16CF

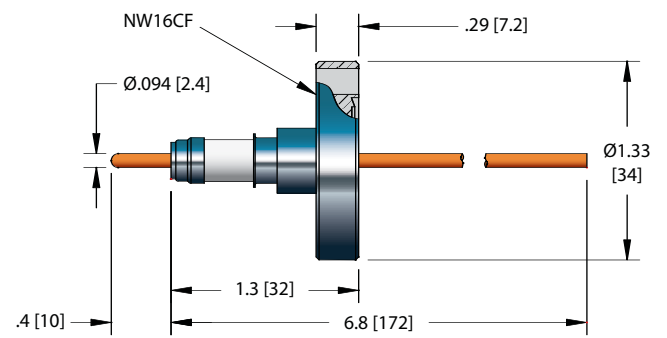

ISO KF - NW40KF

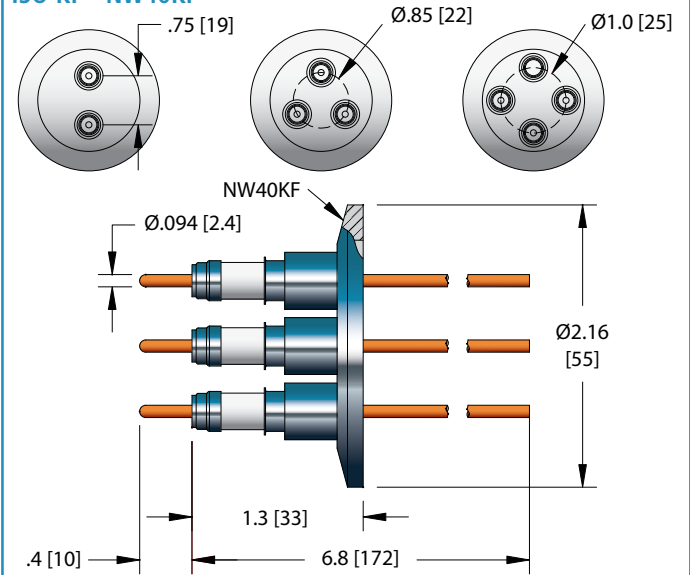

ConFlat - NW35CF

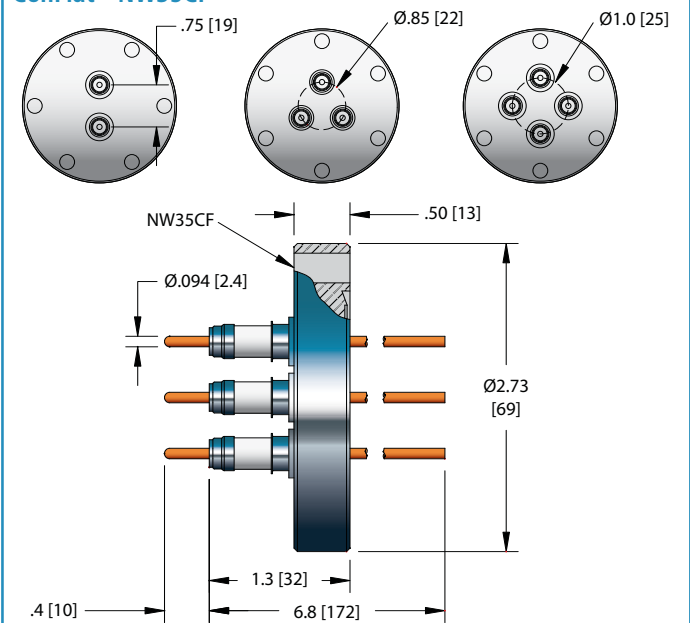

10 KV Power Plug

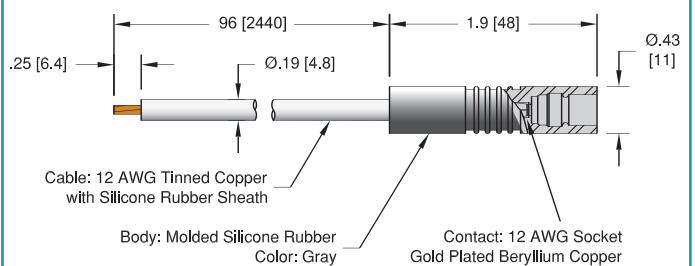

Specifications

Materials

- Housing: 304 Stainless steel
- Pin: See table
- Insulation: Alumina ceramic
- Magnetic Materials: See table

Voltage Rating 10 kV DC*

Current Rating See table

Temperature Range -269°C to 450°C, ISO KF -25°C to 205°C

Pressure @ 20°C 1500 PSIG (103 Bar), ISO KF 0 PSIG

*When used with air side cable assembly.



FEEDTHROUGH



Weldable

NO. PINS	AMPS	CONDUCTOR MATERIAL	INSTALLATION	MAGNETIC MATERIALS	PART NUMBER
1	3.6	304 Stn. Stl.	Weld	No	3888-08-W
1	16.5	Nickel	Weld	Yes	3888-09-W
1	55	Copper	Weld	No	3888-10-W



ISO KF

ISO FLANGE					
1	3.6	304 Stn. Stl.	NW16KF	No	17026-05-KF
1	16.5	Nickel	NW16KF	Yes	17026-06-KF
1	55	Copper	NW16KF	No	17026-08-KF
2	3.6	304 Stn. Stl.	NW40KF	No	17027-05-KF
2	16.5	Nickel	NW40KF	Yes	17027-06-KF
2	55	Copper	NW40KF	No	17027-08-KF
3	3.6	304 Stn. Stl.	NW40KF	No	17067-05-KF
3	16.5	Nickel	NW40KF	Yes	17067-06-KF
3	55	Copper	NW40KF	No	17067-08-KF
4	3.6	304 Stn. Stl.	NW40KF	No	17028-05-KF
4	16.5	Nickel	NW40KF	Yes	17028-06-KF
4	55	Copper	NW40KF	No	17028-08-KF

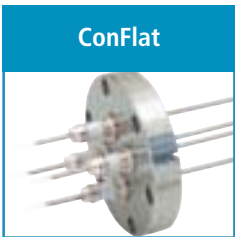

ConFlat

CONFLAT FLANGE					
1	3.6	304 Stn. Stl.	1 1/3" (NW16CF)	No	19542-07-CF
1	16.5	Nickel	1 1/3" (NW16CF)	Yes	19542-03-CF
1	55	Copper	1 1/3" (NW16CF)	No	19542-04-CF
2	3.6	304 Stn. Stl.	2 3/4" (NW35CF)	No	17060-05-CF
2	16.5	Nickel	2 3/4" (NW35CF)	Yes	17060-06-CF
2	55	Copper	2 3/4" (NW35CF)	No	17060-08-CF
3	3.6	304 Stn. Stl.	2 3/4" (NW35CF)	No	17064-05-CF
3	16.5	Nickel	2 3/4" (NW35CF)	Yes	17064-06-CF
3	55	Copper	2 3/4" (NW35CF)	No	17064-08-CF
4	3.6	304 Stn. Stl.	2 3/4" (NW35CF)	No	17069-05-CF
4	16.5	Nickel	2 3/4" (NW35CF)	Yes	17069-06-CF
4	55	Copper	2 3/4" (NW35CF)	No	17069-08-CF



Air Side Cable Assembly

TYPE	CABLE TYPE	LENGTH	CONDUCTOR AMPS	TEMPERATURE °C MIN	TEMPERATURE °C MAX	PART NUMBER
10 kV Power Plug	12 AWG	8'	30	-55	125	14418-02-A

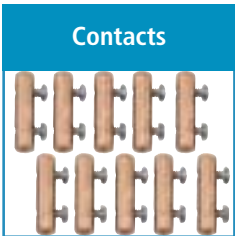

Contacts

TYPE	MATERIAL	DESCRIPTION	PART NUMBER
0.094 Set Screw Type Contacts	Beryllium Copper	Accepts wire up to 0.050 [1.3]	7429-01-A
0.094 Barrel Type Contacts	Beryllium Copper	Accepts wire up to 0.094 [2.4]	7332-04-A [†]
Crimp Tool		For 0.025" - 0.075" Crimp Diameters	2840-05

*When used with air side cable assembly. **Contacts priced and sold in packages of 10. [†]Shown in photo. See the Accessories section for more information on all accessories.

