

Weldable

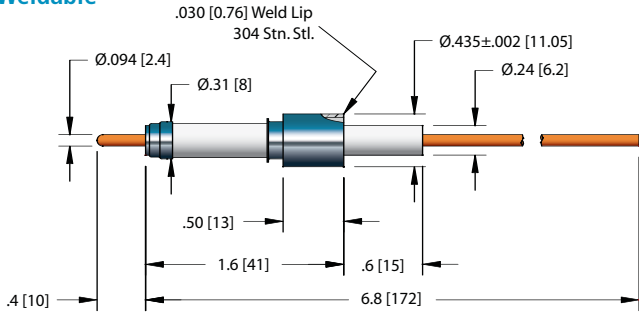

ISO KF - NW16KF

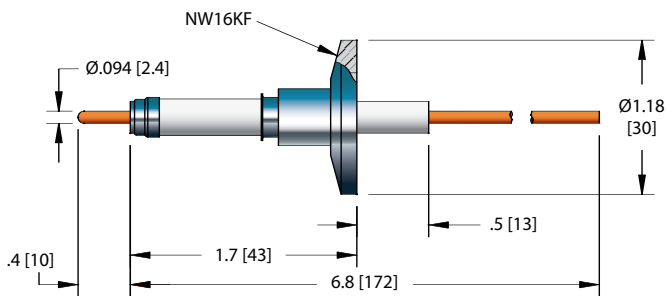

ConFlat - NW16CF

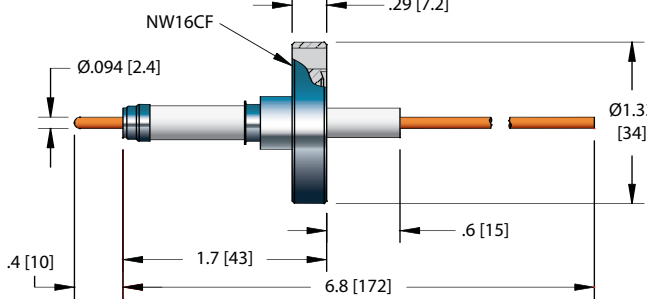

ISO KF - NW40KF

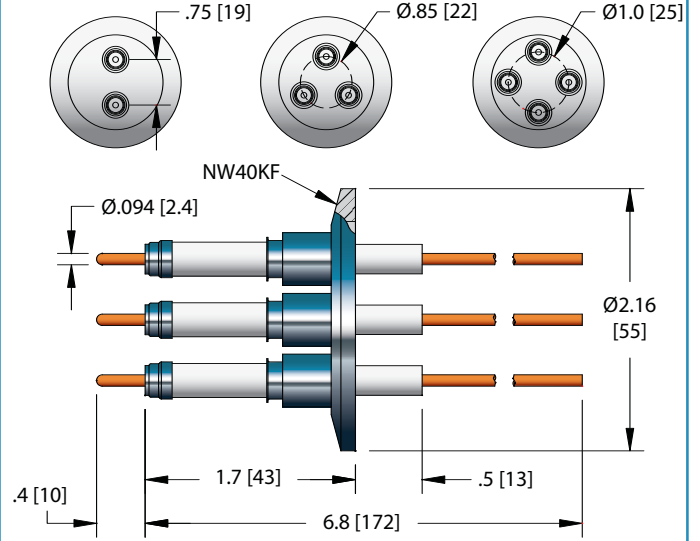

ConFlat - NW35CF

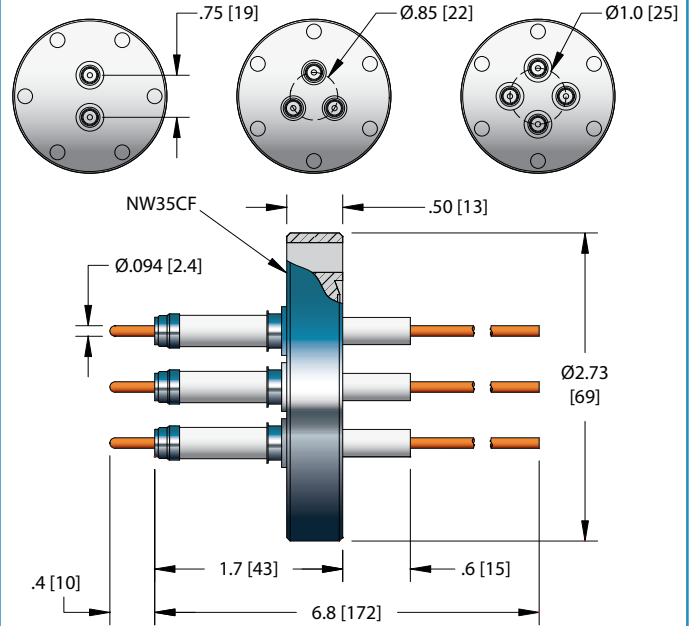

Specifications

Materials

- Housing: 304 Stainless steel
- Pin: See table
- Insulation: Alumina ceramic
- Magnetic Materials: See table

Voltage Rating 20 kV DC*

Current Rating See table

Temperature Range -269°C to 450°C, ISO KF -25°C to 205°C

Pressure @ 20°C 1500 PSIG (103 Bar), ISO KF 0 PSIG

*When used with air side cable assembly.

20 KV Power Plug

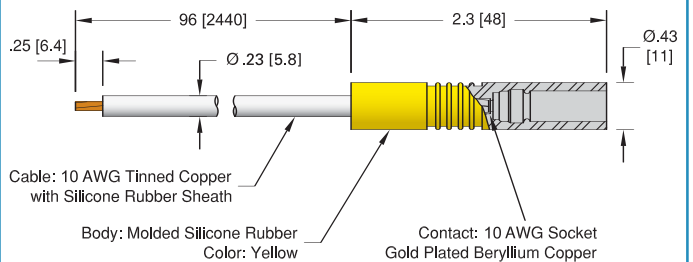



Weldable

NO. PINS	AMPS	CONDUCTOR MATERIAL	INSTALLATION	MAGNETIC MATERIALS	PART NUMBER
1	3.6	304 Stn. Stl.	Weld	No	17575-03-W
1	16.5	Nickel	Weld	Yes	4275-22-W
1	55	Copper	Weld	No	4275-21-W

ISO KF

ISO FLANGE

1	3.6	304 Stn. Stl.	NW16KF	No	17036-05-KF
1	16.5	Nickel	NW16KF	Yes	17036-06-KF
1	55	Copper	NW16KF	No	17036-08-KF
2	3.6	304 Stn. Stl.	NW40KF	No	17037-05-KF
2	16.5	Nickel	NW40KF	Yes	17037-06-KF
2	55	Copper	NW40KF	No	17037-08-KF
3	3.6	304 Stn. Stl.	NW40KF	No	17068-05-KF
3	16.5	Nickel	NW40KF	Yes	17068-06-KF
3	55	Copper	NW40KF	No	17068-08-KF
4	3.6	304 Stn. Stl.	NW40KF	No	17038-05-KF
4	16.5	Nickel	NW40KF	Yes	17038-06-KF
4	55	Copper	NW40KF	No	17038-08-KF

ConFlat

CONFLAT FLANGE

1	3.6	304 Stn. Stl.	1 1/3" (NW16CF)	No	19543-07-CF
1	16.5	Nickel	1 1/3" (NW16CF)	Yes	19543-03-CF
1	55	Copper	1 1/3" (NW16CF)	No	19543-04-CF
2	3.6	304 Stn. Stl.	2 3/4" (NW35CF)	No	10287-04-CF
2	16.5	Nickel	2 3/4" (NW35CF)	Yes	10287-05-CF
2	55	Copper	2 3/4" (NW35CF)	No	10287-03-CF
3	3.6	304 Stn. Stl.	2 3/4" (NW35CF)	No	17065-05-CF
3	16.5	Nickel	2 3/4" (NW35CF)	Yes	17065-06-CF
3	55	Copper	2 3/4" (NW35CF)	No	17065-08-CF
4	3.6	304 Stn. Stl.	2 3/4" (NW35CF)	No	16709-16-CF
4	16.5	Nickel	2 3/4" (NW35CF)	Yes	16709-08-CF
4	55	Copper	2 3/4" (NW35CF)	No	16709-10-CF

Air Side Cable Assembly

TYPE	CABLE TYPE	LENGTH	CONDUCTOR AMPS	TEMPERATURE °C MIN	TEMPERATURE °C MAX	PART NUMBER
20 kV Power Plug	10 AWG	8'	55	-55	125	14419-02-A

Contacts

TYPE	MATERIAL	DESCRIPTION	PART NUMBER
0.094 Set Screw Type Contacts	Beryllium Copper	Accepts wire up to 0.050 [1.3]	7429-01-A
0.094 Barrel Type Contacts	Beryllium Copper	Accepts wire up to 0.094 [2.4]	7332-04-A [†]

*When used with air side cable assembly. **Contacts priced and sold in packages of 10. [†]Shown in photo. See the Accessories section for more information on all accessories.

