

Weldable

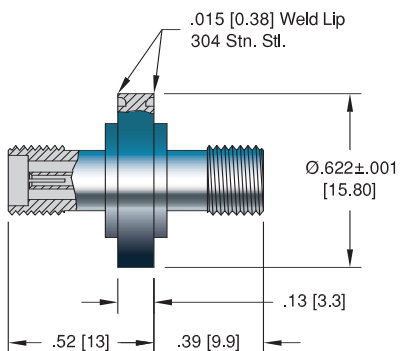

ISO KF – NW25KF

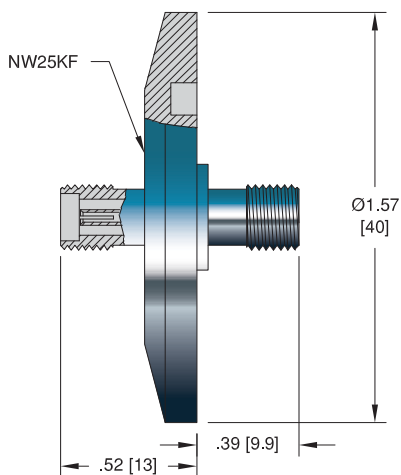

ConFlat – NW16CF

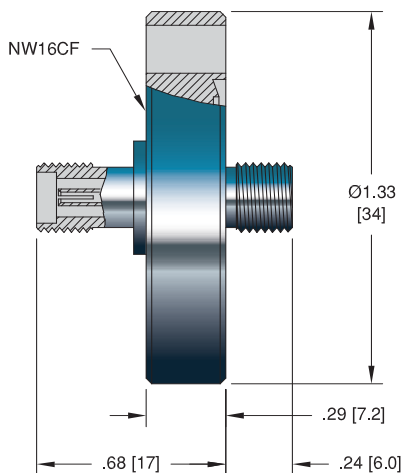

ISO KF

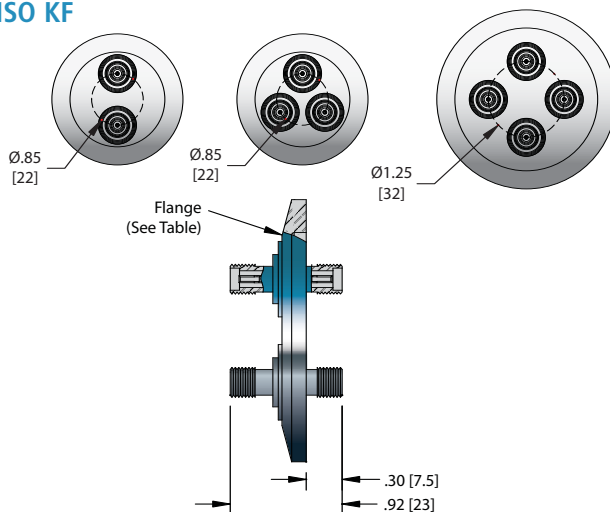

ConFlat

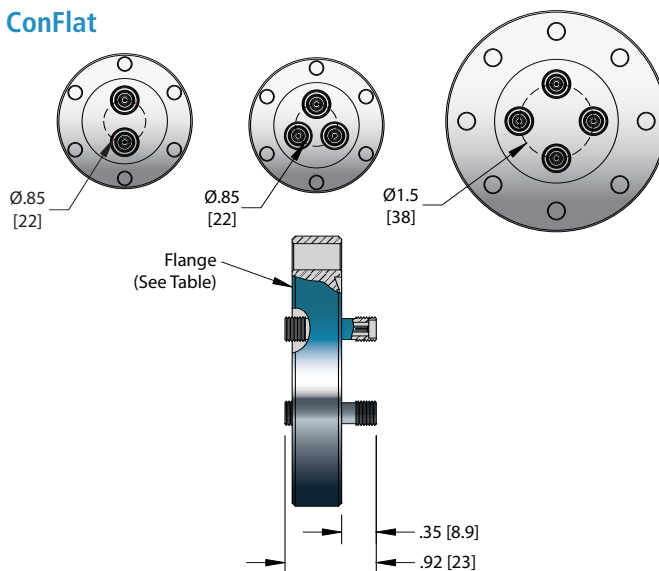

Specifications

Materials

Housing: 304 Stainless steel Insulation: Glass-ceramic
 Pin: Inconel X-750 Magnetic Materials: No
 Contacts: 300 Series Stn. Stl.

Voltage Rating 500 V DC

Current Rating 1 Amp

Temperature Range -269°C to 350°C, ISO KF -25°C to 205°C

Pressure @ 20°C 1400 PSIG (97 Bar), ISO KF 0 PSIG



NO. PINS	INSTALLATION	PART NUMBER
1	Weld	15263-03-W

ISO FLANGE



1	NW25KF	18055-02-KF
2	NW40KF	21365-01-KF
3	NW40KF	21366-01-KF
4	NW50KF	21367-01-KF

CONFLAT FLANGE



1	1 1/3" (NW16CF)	16545-01-CF
2	2 3/4" (NW35CF)	21362-01-CF
3	2 3/4" (NW35CF)	21363-01-CF
4	4 1/2" (NW63CF)	21364-01-CF



TYPE	VOLTAGE DC	CONDUCTOR AMPS	DIMENSIONS H L		DESCRIPTION	PART NUMBER
Air Side	500 V	5	0.31 [7.9]	0.98 [25]	SMA Plug	6524-02



TYPE	LENGTH	VOLTAGE DC	CONDUCTOR AMPS	TEMPERATURE MIN MAX		PART NUMBER
50 Ohm SMA – Double Ended	10'	500 V	5	-70	200	21617-01-A

See the Accessories section for more information on all accessories.

