

Feedthrough

Specifications

Materials

Shell: 304 Stainless steel
 Thermocouple materials:
 Chromel/Alumel (Type K)
 Tungsten-Rhenium (Type C)
 Pins: Nickel or Copper
 Insulation: Alumina ceramic
 Magnetic Materials: Yes

Voltage Rating 5 kV DC

Current Rating See table

Temperature Range -269°C to 450°C

Pressure @ 20°C 500 PSIG (34 Bar), ISO KF 0 PSIG

Multipin Connector

Coaxial

Thermocouple

Isolator

Viewport

Pressure

Accessories

Technical Reference

Weldable

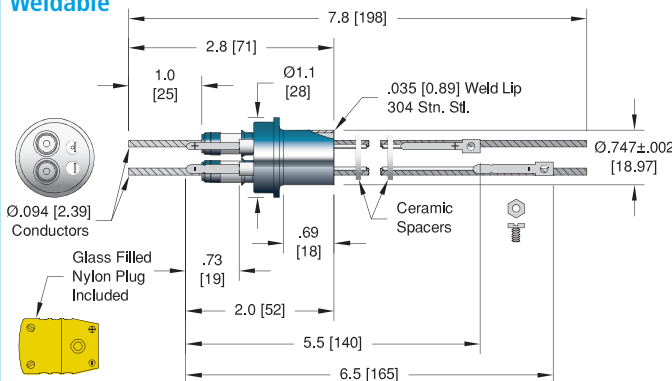

ISO KF

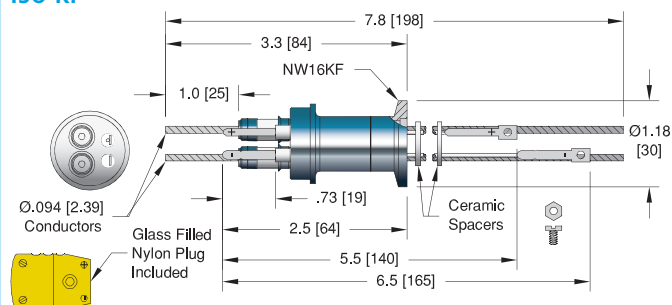

ConFlat - NW16CF

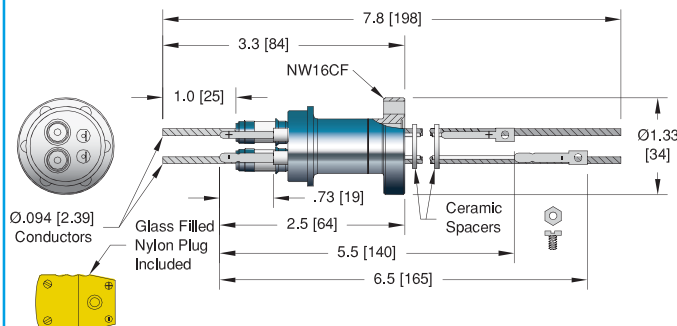

ConFlat - NW35CF

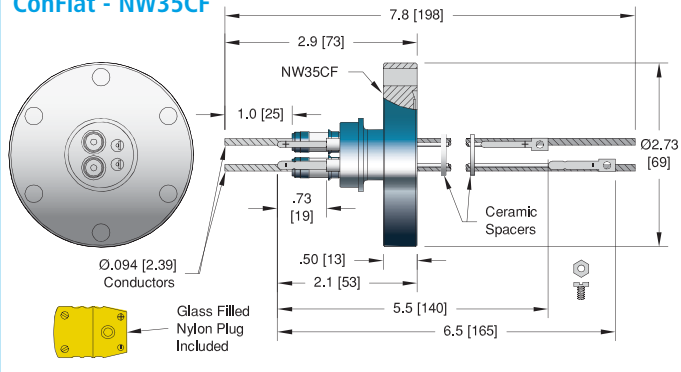

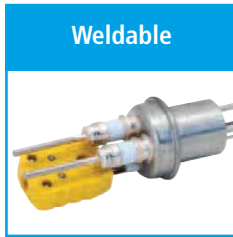

Weldable

ANSI TYPE	THERMOCOUPLE MATERIALS	INSTALLATION	CONDUCTOR		PART NUMBER
			AMPS	MATERIAL	
K	Chromel/Alumel	Weld	16.5	Nickel	3181-02-W
K	Chromel/Alumel	Weld	55	Copper	3181-01-W
C	Tungsten-Rhenium**	Weld	16.5	Nickel	0572-02-W
C	Tungsten-Rhenium**	Weld	55	Copper	0572-01-W



ISO KF

ISO FLANGE					
K	Chromel/Alumel	NW16KF	16.5	Nickel	18007-01-KF
K	Chromel/Alumel	NW16KF	55	Copper	18007-02-KF
C	Tungsten-Rhenium**	NW16KF	16.5	Nickel	18007-05-KF
C	Tungsten-Rhenium**	NW16KF	55	Copper	18007-06-KF

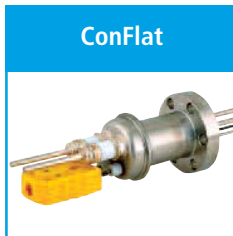

ConFlat

CONFLAT FLANGE					
K	Chromel/Alumel	1 1/3" (NW16CF)	16.5	Nickel	8878-07-CF
K	Chromel/Alumel	1 1/3" (NW16CF)	55	Copper	8878-01-CF
C	Tungsten-Rhenium**	1 1/3" (NW16CF)	16.5	Nickel	8878-06-CF
C	Tungsten-Rhenium**	1 1/3" (NW16CF)	55	Copper	8878-02-CF
K	Chromel/Alumel	2 3/4" (NW35CF)	16.5	Nickel	10586-06-CF
K	Chromel/Alumel	2 3/4" (NW35CF)	55	Copper	10586-01-CF
C	Tungsten-Rhenium**	2 3/4" (NW35CF)	16.5	Nickel	10586-08-CF
C	Tungsten-Rhenium**	2 3/4" (NW35CF)	55	Copper	10586-02-CF



Air Side Plug

ANSI TYPE	THERMOCOUPLE MATERIALS	TYPE	MATERIALS	TEMPERATURE °C		COLOR CODE	PART NUMBER
				MIN	MAX		
K	Chromel/Alumel	Standard	Glass Filled Nylon	-29	218	Yellow	08151-01
K	Chromel/Alumel	High Temp	Ceramic	-73	650	Yellow	08151-09
C	Tungsten-Rhenium**	Standard	Glass Filled Nylon	-29	218	Red	08151-04
C	Tungsten-Rhenium**	High Temp	Ceramic	-73	250	Red	08151-07

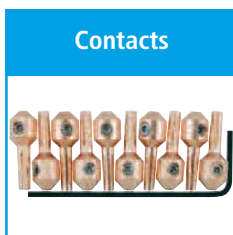

Contacts

TYPE	MATERIAL	DESCRIPTION	PART NUMBER
0.094 Set Screw Type Contacts	Beryllium Copper	Accepts wire up to 0.050 [1.3]	7429-01-A†
0.094 Barrel Type Contacts	Beryllium Copper	Accepts wire up to 0.094 [2.4]	7332-04-A

*Contacts priced and sold in packages of 10. **Uses compensating wire. Maximum junction temperature 250° C. †Shown in photo. See the Accessories section for more information on all accessories.

Feedthrough
Multipin Connector
Coaxial
Thermocouple
Isolator
Viewport
Pressure
Accessories
Technical Reference