

Feedthrough

Multipin Connector

Coaxial

Thermocouple

Isolator

Viewport

Pressure

Accessories

Technical Reference

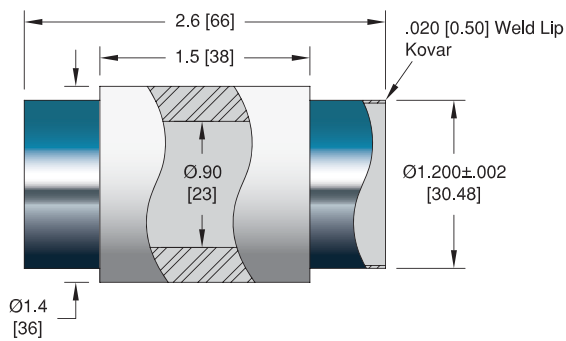
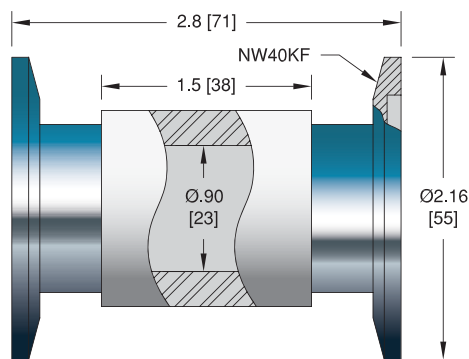
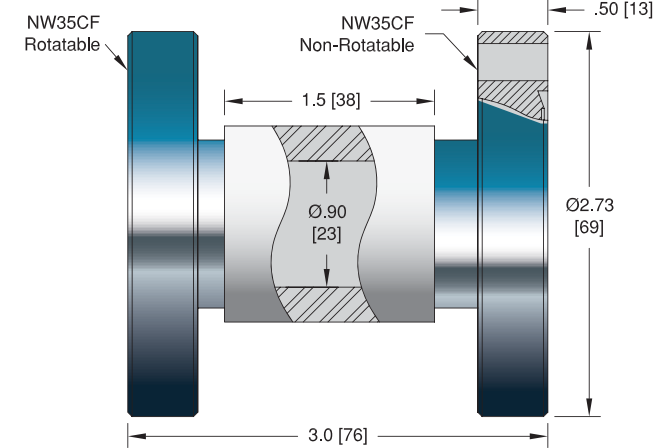
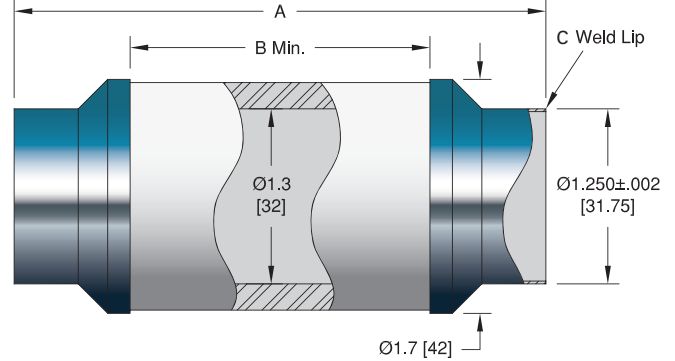
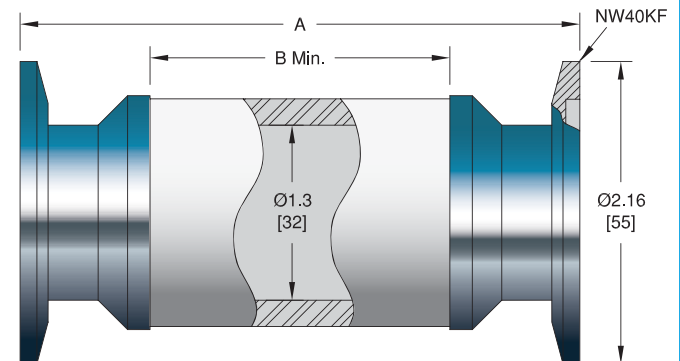
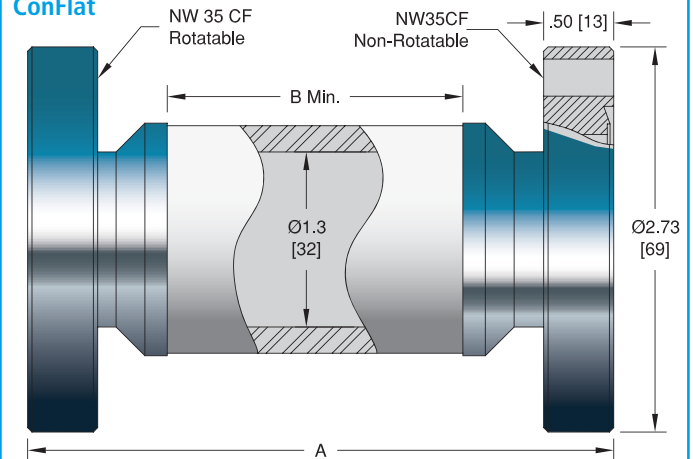
Insulator ID: .90 [23]
Weldable**ISO KF****ConFlat****Insulator ID: 1.3 [32]**
Weldable**ISO KF****ConFlat****Specifications - Insulator ID: .90 [23]****Materials**

Tube: Kovar
 Insulation: Alumina ceramic
 Magnetic Materials: Yes

Voltage Rating 30 kV DC**Temperature Range** -55°C to 450°C, ISO KF -25°C to 205°C**Pressure @ 20°C** See table**Specifications - Insulator ID: 1.3 [32]****Materials**

Tube: Kovar or 304 stainless steel
 Insulation: Alumina ceramic
 Magnetic Materials: See table

Voltage Rating See table**Temperature Range** See table**Pressure @ 20°C** See table

Weldable
ID: .90 [23]



VOLTAGE DC	INSTALLATION	PRESSURE @ 20 °C BAR		PART NUMBER
30 kV	Weld	360	24	9997-09-W

ISO KF
ID: .90 [23]



ISO FLANGE

30 kV	NW40KF	-	-	17237-01-KF
-------	--------	---	---	-------------

ConFlat
ID: .90 [23]



CONFLAT FLANGE

30 kV	2 3/4" (NW35CF)	360	24	4511-02-CF
-------	-----------------	-----	----	------------

Weldable
ID: 1.3 [32]



VOLTAGE DC	INSTALLATION	DIMENSIONS			PRESSURE @ 20 °C		TEMP °C		MAGNETIC MATERIALS	PART NUMBER	
		A	B	C	PSIG	BAR	MIN	MAX			
5 kV	Weld	1.9 [49]	0.6 [4.0]	.020 [0.50]	Kovar	350	24	-55	450	Yes	9999-03-W
35 kV	Weld	3.8 [96]	2.0 [50]	.020 [0.50]	Kovar	350	24	-55	450	Yes	9999-01-W
65 kV	Weld	5.7 [144]	3.9 [99]	.020 [0.50]	Kovar	350	24	-55	450	Yes	9999-04-W
5 kV	Weld	1.9 [49]	0.6 [4.0]	.035 [0.90]	Stn.Stl.	250	17	-269	450	No	17199-01-W
35 kV	Weld	3.8 [96]	2.0 [50]	.035 [0.90]	Stn.Stl.	250	17	-269	450	No	17199-02-W
65 kV	Weld	5.7 [144]	3.9 [99]	.035 [0.90]	Stn.Stl.	250	17	-269	450	No	17199-03-W

ISO KF
ID: 1.3 [32]



ISO FLANGE

5 kV	NW40KF	2.1 [54]	0.16 [4.0]	-	-	-	-25	205	Yes	17238-01-KF
35 kV	NW40KF	4.0 [101]	2.0 [50]	-	-	-	-25	205	Yes	17238-02-KF
65 kV	NW40KF	5.9 [149]	3.9 [99]	-	-	-	-25	205	Yes	17238-03-KF
5 kV	NW40KF	2.1 [54]	0.16 [4.0]	-	-	-	-25	205	No	17238-04-KF
35 kV	NW40KF	4.0 [101]	2.0 [50]	-	-	-	-25	205	No	17238-05-KF
65 kV	NW40KF	5.9 [149]	3.9 [99]	-	-	-	-25	205	No	17238-06-KF

ConFlat
ID: 1.3 [32]



CONFLAT FLANGE

5 kV	2 3/4"(NW35CF)	2.3 [59]	0.16 [4.0]	-	350	24	-55	450	Yes	8001-03-CF
35 kV	2 3/4"(NW35CF)	4.2 [107]	2.0 [50]	-	350	24	-55	450	Yes	8001-02-CF
65 kV	2 3/4"(NW35CF)	6.1 [155]	3.9 [99]	-	350	24	-55	450	Yes	8001-04-CF
5 kV	2 3/4"(NW35CF)	2.3 [59]	0.16 [4.0]	-	250	17	-269	450	No	8001-06-CF
35 kV	2 3/4"(NW35CF)	4.2 [107]	2.0 [50]	-	250	17	-269	450	No	8001-07-CF
65 kV	2 3/4"(NW35CF)	6.1 [155]	3.9 [99]	-	250	17	-269	450	No	8001-08-CF

Feedthrough

Multi-pin Connector

Coaxial

Thermocouple

Isolator

Viewport

Pressure

Accessories

Technical Reference